

STATE OF FLORIDA  
DEPARTMENT OF TRANSPORTATION

CONTRACT PLANS

FINANCIAL PROJECT ID 238275-2-52-01

LAKE COUNTY (11130)

STATE ROAD NO. 46

SIGNALIZATION PLANS

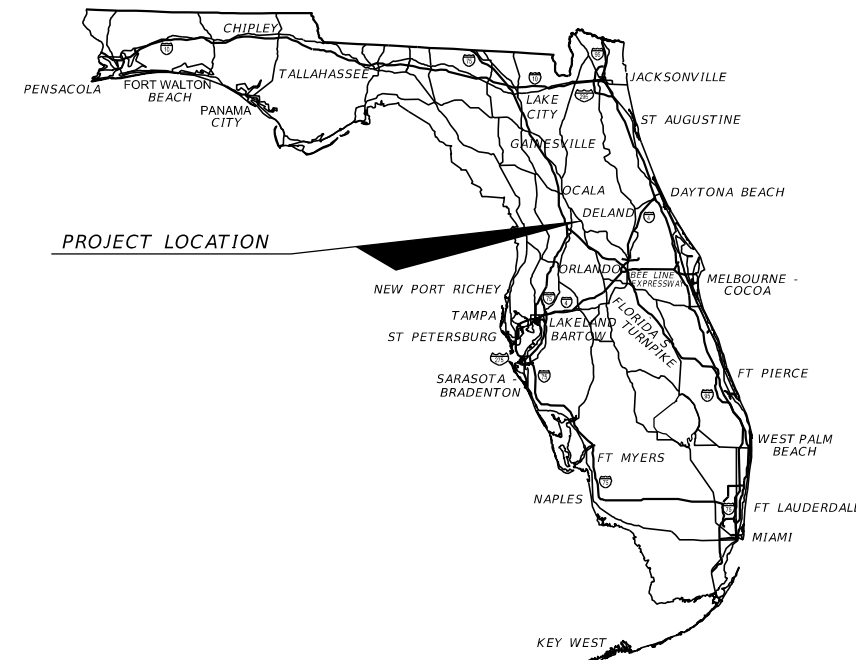

INDEX OF SIGNALIZATION PLANS

SHEET NO.	SHEET DESCRIPTION
T-1	KEY SHEET
T-2	SIGNATURE SHEET
T-3	TABULATION OF QUANTITIES
T-4	PROJECT NOTES
T-5 - T-6	SIGNALIZATION PLAN
T-7	GUIDE SIGN WORKSHEET
T-8	MAST ARM TABULATION
T-9	STANDARD MAST ARM ASSEMBLIES DATA TABLE
T-10	REPORT OF SPT BORINGS RESULTS FOR MASP
T-11	TRAFFIC MONITORING SITE

**SIGNALIZATION SHOP DRAWINGS  
TO BE SUBMITTED TO:**  
SCOTT G. HORLANDER, P.E.  
P.E. NO. 46624  
PROTEAN DESIGN GROUP  
100 EAST PINE STREET, SUITE 600  
ORLANDO FLORIDA 32801  
PHONE (407) 246-0044  
CERTIFICATE OF AUTHORIZATION NUMBER 7865

**PLANS PREPARED BY:**  
PROTEAN DESIGN GROUP  
100 EAST PINE STREET, SUITE 600  
ORLANDO FLORIDA 32801  
PHONE (407) 246-0044  
VENDOR NO. F59-3473441  
CONTRACT NO. C9886  
CERTIFICATE OF AUTHORIZATION NO. 7865

NOTE: THE SCALE OF THESE PLANS MAY  
HAVE CHANGED DUE TO REPRODUCTION.

NOTE: THIS PROJECT IS TO BE LET TO  
CONTRACT WITH FINANCIAL PROJECT  
ID 238275-3-52-01.

**PLANS UPDATE  
3/24/16**

KEY SHEET REVISIONS	
DATE	DESCRIPTION

SIGNALIZATION PLANS  
ENGINEER OF RECORD: SCOTT G. HORLANDER, P.E.

P.E. NO.: 46624

FISCAL YEAR	SHEET NO.
17	T-1

FDOT PROJECT MANAGER: MEDHAT HASSAN, P.E.

NOTICE: THE OFFICIAL RECORD OF THIS SHEET IS THE ELECTRONIC FILE DIGITALLY SIGNED AND SEALED UNDER RULE 61G15-23.004, F.A.C.

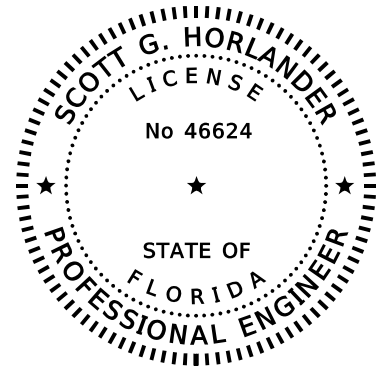

THIS DOCUMENT HAS BEEN DIGITALLY SIGNED AND SEALED BY:

PRINTED COPIES OF THIS DOCUMENT ARE NOT CONSIDERED SIGNED AND SEALED. THIS SIGNATURE MUST BE VERIFIED ON THE ELECTRONIC DOCUMENTS.

PROTEAN DESIGN GROUP  
100 EAST PINE STREET, SUITE 600  
ORLANDO, FLORIDA 32801  
CERTIFICATE OF AUTHORIZATION NUMBER 7865  
SCOTT G. HORLANDER, P.E. NO. 46624

THE ABOVE NAMED PROFESSIONAL ENGINEER SHALL BE RESPONSIBLE FOR THE FOLLOWING SHEETS IN ACCORDANCE WITH RULE 61G15-23.004, F.A.C.

SIGNALS PLANS

SHEET NO.	DESCRIPTION
T-1	KEY SHEET
T-2	SIGNATURE SHEET
T-3	TABULATION OF QUANTITIES
T-4	PROJECT NOTES
T-5 - T-6	SIGNALIZATION PLAN
T-7	GUIDE SIGN WORKSHEET
T-8	MAST ARM TABULATION
T-11	TRAFFIC MONITORING SITE

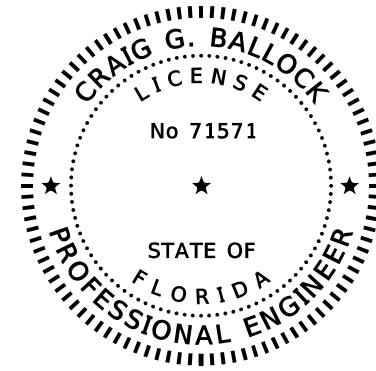

THIS DOCUMENT HAS BEEN DIGITALLY SIGNED AND SEALED BY:

PRINTED COPIES OF THIS DOCUMENT ARE NOT CONSIDERED SIGNED AND SEALED. THIS SIGNATURE MUST BE VERIFIED ON THE ELECTRONIC DOCUMENTS.

GEOTECHNICAL AND ENVIRONMENTAL CONSULTANTS, INC. (GEC)  
919 LAKE BALDWIN LANE  
ORLANDO, FLORIDA 32814  
CERTIFICATE OF AUTHORIZATION NUMBER 5882  
CRAIG G. BALLOCK, P.E. NO. 71571

THE ABOVE NAMED PROFESSIONAL ENGINEER SHALL BE RESPONSIBLE FOR THE FOLLOWING SHEETS IN ACCORDANCE WITH RULE 61G15-23.004, F.A.C.

SIGNALS PLANS

SHEET NO.	DESCRIPTION
T-2	SIGNATURE SHEET
T-10	REPORT OF SPT BORINGS RESULTS FOR MASP

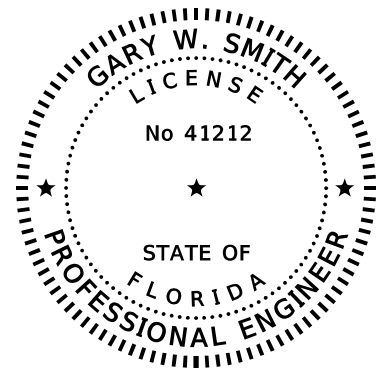

THIS DOCUMENT HAS BEEN DIGITALLY SIGNED AND SEALED BY:

PRINTED COPIES OF THIS DOCUMENT ARE NOT CONSIDERED SIGNED AND SEALED. THIS SIGNATURE MUST BE VERIFIED ON THE ELECTRONIC DOCUMENTS.

MOFFATT & NICHOL  
1025 GREENWOOD BLVD., STE 371  
LAKE MARY, FLORIDA 32746  
CERTIFICATE OF AUTHORIZATION NUMBER 4877  
GARY SMITH, P.E. NO. 41212

THE ABOVE NAMED PROFESSIONAL ENGINEER SHALL BE RESPONSIBLE FOR THE FOLLOWING SHEETS IN ACCORDANCE WITH RULE 61G15-23.004, F.A.C.

SIGNALS PLANS

SHEET NO.	DESCRIPTION
T-2	SIGNATURE SHEET
T-9	STANDARD MAST ARM ASSEMBLIES DATA TABLE

REVISIONS				SCOTT G. HORLANDER, P.E. P.E. NO. 46624 PROTEAN DESIGN GROUP 100 EAST PINE STREET, SUITE 600 ORLANDO FLORIDA 32801 CERTIFICATE OF AUTHORIZATION NUMBER 7865	STATE OF FLORIDA DEPARTMENT OF TRANSPORTATION			SIGNATURE SHEET	SHEET NO.
DATE	DESCRIPTION	DATE	DESCRIPTION		ROAD NO.	COUNTY	FINANCIAL PROJECT ID		
					SR 46	LAKE	238275-2-52-01		

TABULATION OF QUANTITIES

PAY ITEM NO.	DESCRIPTION	UNIT	SHEET NUMBERS																				TOTAL THIS SHEET		GRAND TOTAL		REF. SHEET
			T-5		T-6		T-11																				
			PLAN	FINAL	PLAN	FINAL	PLAN	FINAL	PLAN	FINAL	PLAN	FINAL	PLAN	FINAL	PLAN	FINAL	PLAN	FINAL	PLAN	FINAL	PLAN	FINAL	PLAN	FINAL			
630-2-11	CONDUIT, F&I, OPEN TRENCH	LF	675				270																945		945		
630-2-12	CONDUIT, F&I, DIRECTIONAL BORE	LF	132				66																198		198		
630-2-15	CONDUIT, F&I, BRIDGE MOUNT	LF	717																				717		717		
632-7-1	SIGNAL CABLE, F&I	PI	1																				1		1		
635-2-11	PULL & SPLICE BOX, F&I, 13"X24"	EA	15				3																18		18		
639-1-121	ELEC. POWER SERVICE, F&I, UG, METER FURNISHED BY POWER COMPANY	AS	1																				1		1		
639-2-1	ELEC. SERVICE WIRE	LF	106																				106		106		
641-2-11	PRESTRESSED CONC POLE, F&I, P-11 PEDESTAL	EA	1																				1		1		
646-1-11	ALUMINUM SIGNALS POLE, F&I, PEDESTAL	EA	8																				8		8		
649-31-302	STEEL MAST ARM ASSEMBLY, F&I, 110 W/ BACKPLATES, 46'	EA	1																				1		1		
649-31-304	STEEL MAST ARM ASSEMBLY, F&I, 110 W/ BACKPLATES, 70.5'	EA	1																				1		1		
650-1-14	TRAFFIC SIGNAL, F&I, ALUMINUM, 3 SECTION, 1 WAY	AS			15																		15		15		
650-1-16	TRAFFIC SIGNAL, F&I, ALUMINUM, 4 SECTION, 1 WAY	AS			4																		4		4		
653-1-11	PEDESTRIAN SIGNAL, F&I, LED-COUNTDOWN, 1 WAY	AS			8																		8		8		
660-4-11	VEHICLE DET. SYS., VIDEO, F&I, CABINET EQUIPMENT	EA	1																				1		1		
660-4-12	VEHICLE DET. SYS., VIDEO, F&I, ABOVE GROUND EQUIPMENT	EA	6																				6		6		
663-1-110	SIGNAL PRE-EMPTION, F&I, OPTICAL, COMPLETE SYSTEM	AS	1																				1		1		
665-1-11	PEDESTRIAN DETECTOR, F&I, STANDARD	EA	8																				8		8		
670-5-111	TRAFFIC CONTRL. ASSEMBLY, F&I, NEMA, 1 PRE-EMPTION	AS	1																				1		1		
695-1-1	TMS VEHICLE SENSOR-NON-WEIGHT, F&I	EA					6																6		6		
695-6-12	TMS INDUCTIVE LOOP ASSEMBLY, F&I, 2 LOOPS	AS					6																6		6		
695-7-132	TMS CABINET, F&I, TYPE III, PEDESTAL	EA					1																1		1		
700-5-22	INTERNALLY ILLUMINATED SIGN, F&I, 12-18 SF	EA			6																		6		6		

PAY ITEM NOTES

- PAY ITEM NUMBER 102-14 INCLUDES PROVIDING A TRAFFIC CONTROL OFFICER FOR TRAFFIC CONTROL WHEN SIGNALS ARE NOT IN USE.
- PAY ITEM NUMBER 639-1-121 TO INCLUDE ALL FEES BY THE POWER COMPANY FOR ENERGIZING THE POWER SERVICE. THE CONTRACTOR SHALL VERIFY THE POWER SERVICE REQUIREMENTS (CITY OF MOUNT DORA, ELECTRIC) PRIOR TO BIDDING THE PROJECT.
- PAY ITEM NUMBER 646-1-11 SHALL INCLUDE A SLIP BASE.
- PAY ITEM NUMBER 665-1-11 SHALL INCLUDE FTP-68B-06.
- PAY ITEM NUMBERS 600-4-12, 700-5-22 AND 650-1-AB SHALL INCLUDE ALL NECESSARY HARDWARE REQUIRED FOR PROPER MOUNTING.

REVISIONS				SCOTT G. HORLANDER, P.E. P.E. NO. 46624 PROTEAN DESIGN GROUP 100 EAST PINE STREET, SUITE 600 ORLANDO FLORIDA 32801 CERTIFICATE OF AUTHORIZATION NUMBER 7865	STATE OF FLORIDA DEPARTMENT OF TRANSPORTATION			TABULATION OF QUANTITIES	SHEET NO.  T-3
DATE	DESCRIPTION	DATE	DESCRIPTION		ROAD NO.	COUNTY	FINANCIAL PROJECT ID		
					SR 46	LAKE	238275-2-52-01		

NOTICE: THE OFFICIAL RECORD OF THIS SHEET IS THE ELECTRONIC FILE DIGITALLY SIGNED AND SEALED UNDER RULE 61G15-23.004, F.A.C.

PROJECT NOTES

1. CONTRACTOR IS TO NOTIFY LAKE COUNTY TRAFFIC OPERATIONS (352-742-1766) TWO BUSINESS DAYS PRIOR TO BEGINNING ANY CONSTRUCTION. A PRE-CONSTRUCTION MEETING SHALL BE SCHEDULED WITH LAKE COUNTY TRAFFIC OPERATIONS PRIOR TO ANY CONSTRUCTION.
2. THE CONTRACTOR SHALL CONTACT DISTRICT FIVE MAINTENANCE OFFICE AT (386) 740-3463 FOUR WEEKS PRIOR TO COMPLETION OF THE PROJECT TO REQUEST A STRUCTURE NUMBER AND SCHEDULE A POST CONSTRUCTION INSPECTION OF THE MAST ARMS.
3. THE CONTRACTOR SHALL FURNISH LAKE COUNTY TRAFFIC OPERATIONS WITH EMERGENCY CONTACTS WITH PHONE NUMBERS.
4. THE CONTRACTOR SHALL FURNISH LAKE COUNTY TRAFFIC OPERATIONS TWO COMPLETE SETS OF AS-BUILT PLANS THAT INCLUDE CONDUIT AND PULL BOX LOCATIONS, AT FINAL INSPECTION.
5. THE LOCATION OF KNOWN UTILITIES SHOWN IN THE PLANS IS APPROXIMATE ONLY. THE CONTRACTOR IS RESPONSIBLE FOR IDENTIFYING, AND LOCATING ALL EXISTING UTILITIES WITHIN THE LIMITS OF CONSTRUCTION.

UTILITY/AGENCY OWNERS:	COMPANY CONTACT:	TELEPHONE NUMBER:
CENTURYLINK	WADE RICH	(407) 881-8383
CITY OF MOUNT DORA - WATER/SEWER	JOHN PETERS	(352) 735-7151
CITY OF MOUNT DORA - ELECTRIC	CHARLES REVELL	(352) 735-7155
CITY OF LEESBURG - FIBER OPTIC	JIMMY FEAGLE	(352) 435-9440
COMCAST COMMUNICATIONS	SCOTT OSEBOLD	(352) 315-8527
DUKE ENERGY - DISTRIBUTION	MIKE EDKIN	(407) 942-9553
DUKE ENERGY - TRANSMISSION	ED BURKOT	(407) 942-9453
TECO/PEOPLES GAS	BRUCE STOUT	(407) 420-2678

CONTROLLER

1. THE CONTROLLER ASSEMBLY SHALL CONSIST OF A NEMA TS 2 CABINET WITH A TS2 TYPE 1 CONTROLLER, ETHERNET ENABLED FOR LAKE COUNTY CLOSED LOOP SYSTEM. THE CONTROLLER ASSEMBLY SHALL ALSO INCLUDE A GENERATOR SWITCH BOX PANEL. THE CONTROLLER ASSEMBLY SHALL HAVE ALL NECESSARY HARDWARE TO COMMUNICATE WITH THE LAKE COUNTY INTERCONNECT SIGNAL SYSTEM. ANY ADDITIONAL EQUIPMENT AND/OR ACCESSORIES REQUIRED FOR THE TERMINATION AND OPERATION OF THE FIBER OPTIC INTERCONNECT CABLE SHALL BE FURNISHED AND INSTALLED AS PART OF THE CONTROLLER ASSEMBLY.
2. A MANUAL PUSH-BUTTON CORD SHALL BE FURNISHED IN ALL CONTROLLER CABINETS.
3. THE CONTROLLER CABINET SHALL BE ORIENTED SO THAT THE DOOR OPENS AWAY FROM THE INTERSECTION.
4. A GENERATOR PAD, 3' X 3' X 4" CONCRETE SHALL BE INSTALLED WITH 5/8" EYEBOLT INSTALLED IN THE PAD ADJACENT TO THE CABINET BASE. COST OF CONCRETE PAD TO BE INCLUDED WITH PAY ITEM 670-5-111
5. THE MOUNTING OF ELECTRICAL SERVICE TO THE TRAFFIC SIGNAL CABINET SHALL BE PROHIBITED.
6. THE CONTRACTOR SHALL CONTACT LAKE COUNTY TRAFFIC OPERATIONS AT (352) 741-1766 FOR INFORMATION ON LAKE COUNTY'S PREFERRED SIGNAL EQUIPMENT FOR SIGNAL SYSTEM SYNCHRONIZATION, COMMUNICATION AND MAINTENANCE PRIOR TO BIDDING THE PLANS.

PED. FEATURES

1. ALL PEDESTRIAN SIGNAL HEADS SHALL HAVE LOUVERS AND BE COUNTDOWN LED SIGNALS WITH THE PROPER COUNTDOWN PEDESTRIAN SIGNAGE. ALL PEDESTRIAN SIGNALS SHALL HAVE A BREAKAWAY BASE.

SIGNAL CABLE, LOOPS, CONDUIT, PULL BOXES & VIDEO DETECTION

1. ALL VEHICULAR SIGNAL HEAD ASSEMBLIES SHALL BE BLACK, CAST ALUMINUM, WITH TUNNEL VISORS, AND LED'S FOR ALL INDICATIONS, UNLESS OTHERWISE NOTED.
2. SIGNAL HEADS SHALL BE WIRED DIRECTLY TO THE TERMINAL BLOCKS. THE USE OF "JONES" PLUGS IS PROHIBITED.
3. DISCONNECTS SHALL OPEN FROM THE SIGNAL FACE.

INTERNALLY ILLUMINATED STREET NAME SIGNS

1. INTERNALLY ILLUMINATED STREET NAME SIGNS SHALL BE POWERED BY A SEPARATE CIRCUIT BREAKER AND BE DESIGNED AND INSTALLED IN ACCORDANCE WITH LAKE COUNTY PUBLIC WORKS INTERNALLY ILLUMINATED STREET NAME SIGN DETAIL. A PHOTOCELL SHALL BE INSTALLED NEAR THE ELECTRICAL SERVICE WITHIN REACH OF A LIFT TRUCK. CARE TO BE GIVEN TO INSTALL WHERE STREET LIGHTING DOES NOT AFFECT SIGN OPERATION.

LEGEND:

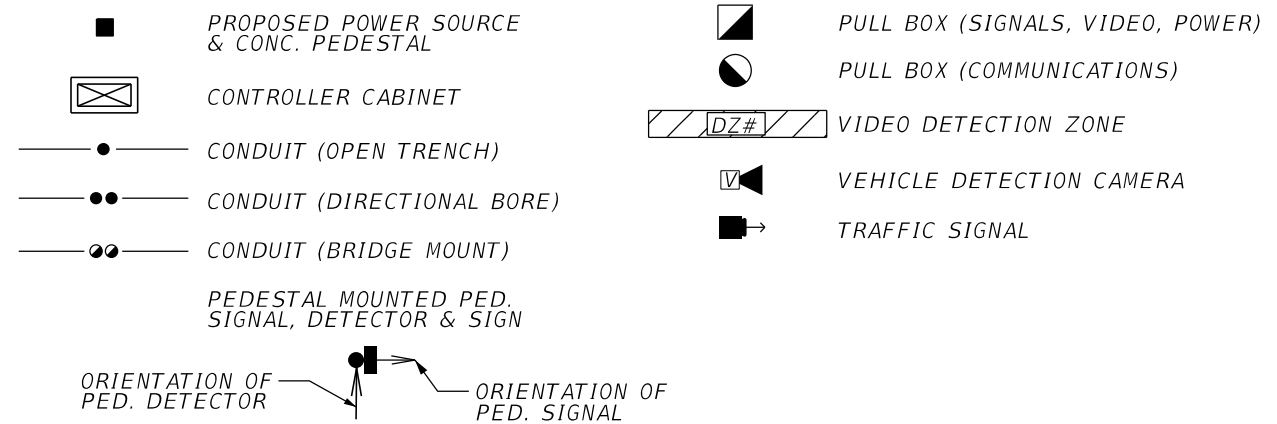

KEY NOTES:

- 1 120/240V, SINGLE PHASE, 3 WIRE ELECTRIC DISTRIBUTION OVERHEAD SERVICE DROP.
- 2 ELECTRICAL SERVICE POINT. PULL BOX BY CONTRACTOR.
- 3 ITS METER SOCKET.
- 4 SIGNALS METER SOCKET.
- 5 ITS SERVICE MAIN DISCONNECT.
- 6 SIGNALS SERVICE MAIN DISCONNECT.
- 7 ITS PULL BOX.
- 8 SIGNALS PULL BOX.
- 9 #6 AWG INSULATED COPPER GROUND WIRE IN 1/2" RGS CONDUIT.
- 10 GROUNDING ELECTRODE.
- 11 UNDERGROUND FEEDER CONDUIT.
- 12 CONCRETE POLE.
- 13 SERVICE FEEDER IN RGS CONDUIT.
- 14 MOUNT ON RISER POLE.
- 15 WEATHERHEAD.

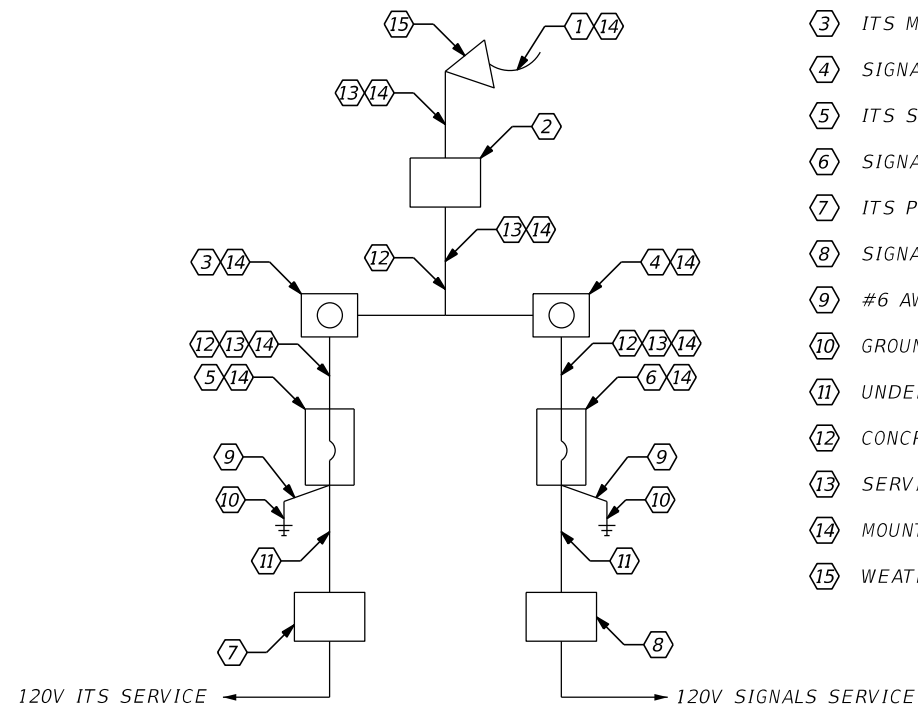

ONE LINE DIAGRAM  
SEE INDEX 17736 FOR ADDITIONAL DETAILS

REVISIONS				SCOTT G. HORLANDER, P.E. P.E. NO. 46624 PROTEAN DESIGN GROUP 100 EAST PINE STREET, SUITE 600 ORLANDO FLORIDA 32801 CERTIFICATE OF AUTHORIZATION NUMBER 7865	STATE OF FLORIDA DEPARTMENT OF TRANSPORTATION			PROJECT NOTES	SHEET NO.
DATE	DESCRIPTION	DATE	DESCRIPTION		ROAD NO.	COUNTY	FINANCIAL PROJECT ID		
						SR 46	LAKE		238275-2-52-01

NOTICE: THE OFFICIAL RECORD OF THIS SHEET IS THE ELECTRONIC FILE DIGITALLY SIGNED AND SEALED UNDER RULE 61G15-23.004, F.A.C.

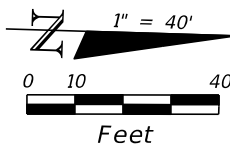

CITY OF MT. DORA  
ELEC. SERVICE POINT\*\*

630-2-11	(CR3 @ 96 LF)
639-1-121	1 AS
639-2-1	96 LF
641-2-11	1 EA

PEDESTAL B  
STA. 443+02.07, 92.04' LT

630-2-11	(CR1 @ 12 LF)
646-1-11	1 EA
665-1-11	1 EA

PEDESTAL A  
STA. 442+96.09, 84.34' LT

630-2-11	(CR1 @ 19 LF)
646-1-11	1 EA
665-1-11	1 EA

PEDESTAL C  
STA. 444+22.66, 86.39' LT

630-2-11	(CR1 @ 24 LF)
646-1-11	1 EA
665-1-11	1 EA

630-2-11	(CR3 @ 10 LF)
639-2-1	10 LF

630-2-11	(5 RUNS @ 10 LF)
632-7-1	1 PI
660-4-11	1 EA
663-1-110	1 AS
670-5-111	1 EA

POLE 1  
STA. 442+80.00, 74.13' LT  
EL. 139.51

630-2-11	(CR6 @ 9 LF)
649-31-304	1 EA

PEDESTAL D  
STA. 444+45.75, 66.00' LT

630-2-11	(CR1 @ 7 LF)
646-1-11	1 EA
665-1-11	1 EA

PEDESTAL H  
STA. 442+96.09, 70.59' RT

630-2-11	(CR1 @ 20 LF)
646-1-11	1 EA
665-1-11	1 EA

PEDESTAL E  
STA. 444+50.75, 58.50' RT

630-2-11	(CR1 @ 5 LF)
646-1-11	1 EA
665-1-11	1 EA

PEDESTAL G  
STA. 443+11.99, 84.55' RT

630-2-11	(CR1 @ 3 LF)
646-1-11	1 EA
665-1-11	1 EA

POLE 2  
STA. 444+40.00, 52.20' RT  
EL. 137.26

630-2-11	(CR6 @ 13 LF)
649-31-302	1 EA

PEDESTAL F  
STA. 444+26.15, 90.13' RT

630-2-11	(CR1 @ 36 LF)
646-1-11	1 EA
665-1-11	1 EA

**NOTES:**

ALL CALLOUTS ARE BASED ON THE CONST. SR 500 UNLESS OTHERWISE NOTED.

\*ROUTE BRIDGE MOUNTED CONDUIT UP PIER 2 INTO PIER DIAPHRAGM FOR BRIDGE MOUNTED SIGNALS, VIDEO DETECTION CAMERAS AND SIGNS. SEE STRUCTURAL PLANS FOR MOUNTING DETAILS.

\*\*CITY OF MT DORA WILL INSTALL CONDUIT & CONDUCTORS FROM SERVICE POLE, THRU SWEEP INTO THE PULL BOX AND MAKE FINAL CONNECTIONS. PULL BOX TO BE INSTALLED BY SIGNAL CONTRACTOR.

REVISIONS				SCOTT G. HORLANDER, P.E. P.E. NO. 46624 PROTEAN DESIGN GROUP 100 EAST PINE STREET, SUITE 600 ORLANDO FLORIDA 32801 CERTIFICATE OF AUTHORIZATION NUMBER 7865	STATE OF FLORIDA DEPARTMENT OF TRANSPORTATION			SIGNALIZATION PLAN SR 500 & SR 46	SHEET NO. T-5
DATE	DESCRIPTION	DATE	DESCRIPTION		ROAD NO.	COUNTY	FINANCIAL PROJECT ID		
					SR 46	LAKE	238275-2-52-01		

NOTICE: THE OFFICIAL RECORD OF THIS SHEET IS THE ELECTRONIC FILE DIGITALLY SIGNED AND SEALED UNDER RULE 61G15-23.004, F.A.C.

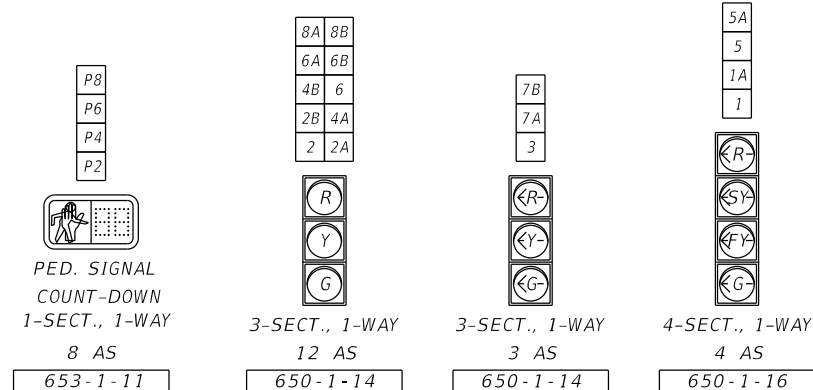

**TABLE 1: TRAFFIC SIGNAL HEAD MOUNTING LOCATION**

TRAFFIC SIGNAL HEAD	STATION*	OFFSET*
1A	217+53.2	6.8' RT
2A	216+54.1	31.8' LT
2B	216+73.6	31.8' LT
3	216+60.6	6.8' RT
4A	216+47.2	31.8' LT
4B	216+62.6	31.8' LT
5A	216+91.9	31.8' LT
6A	217+67.9	6.8' RT
6B	217+82.6	6.8' RT
7A	216+78.4	31.8' LT
7B	216+94.7	31.8' LT
8A	216+76.6	6.8' RT
8B	216+93.3	6.8' RT

\*BASED ON CONST. RAMP XX

**TABLE 2: VIDEO DETECTOR CHART**

VIDEO DETECTOR CAMERA	STATION*	OFFSET*	DETECTION ZONE	DELAY TIME (SEC)
V1	216+93.3	31.8' LT	DZ 5	-
V2	216+58.3	31.8' LT	DZ 2	-
V3	216+76.0	31.8' LT	DZ 4 & 7	-
V4	217+48.9	6.8' RT	DZ 1	-
V5	217+75.2	6.8' RT	DZ 6	-
V6	216+84.9	6.8' RT	DZ 3 & 8	-
			DZ 8R	5

\*BASED ON CONST. RAMP XX  
 DELAY TIME IS INITIAL AND MAY REQUIRE FIELD ADJUSTING AS DIRECTED BY PROJECT ENGINEER.

**TABLE 3: INTERNALLY ILLUMINATED STREET NAME SIGN MOUNTING LOCATION**

STREET NAME SIGN	STATION*	OFFSET*
A1	217+14.6	9.5' RT
A2	216+36.1	34.3' LT
B1	216+18.9	34.5' LT
B2	218+06.1	9.2' RT

\*BASED ON CONST. RAMP XX

**NOTES:**

- THE MAJOR STREET IS SR 500, MOVEMENTS 2 AND 6. THE MINOR STREET IS SR 46, MOVEMENTS 4 AND 8.
- THE DIMENSIONS FOR THE VIDEO DETECTION ZONES ARE AS FOLLOWS:  
 DETECTION ZONES 1, 3, 5 & 8R = 6' x 40'  
 DETECTION ZONES 2 & 6 = 30' x 360'  
 DETECTION ZONES 4, 7 & 8 = 18' x 40'
- TRAFFIC SIGNAL HEADS (650-1-AB) & VEHICLE VIDEO DETECTION CAMERAS (660-4-12) SHALL BE MOUNTED TO THE BOX GIRDER WEBS. INTERNALLY ILLUMINATED STREET NAME SIGNS (700-5-22) SHALL BE MOUNTED TO BRIDGE UNDERDECK. SEE STRUCTURAL PLANS FOR MOUNTING DETAILS AND TABLES 1, 2 & 3 (THIS SHEET) FOR MOUNTING LOCATIONS.

**LEGEND:**

- DZ = VIDEO DETECTION ZONE  
 CR = CONDUIT RUN  
 CR1: 1 RUN W/  
 (1) 2" CONDUIT - SIGNALS  
 CR2: 2 RUNS W/  
 (1) 2" CONDUIT - SIGNALS  
 (1) 2" CONDUIT - SPARE  
 CR3: 1 RUN W/  
 (1) 2" CONDUIT - POWER CONDUCTORS  
 CR4: 2 RUNS W/  
 (1) 2" CONDUIT - SIGNALS  
 (1) 2" CONDUIT - VIDEO DETECTION  
 CR5: 2 RUNS W/  
 (1) 2" CONDUIT - SIGNALS & SIGN  
 (1) 2" CONDUIT - SPARE  
 CR6: 1 RUN W/  
 (1) 2" CONDUIT - SIGNALS & SIGN  
 CR7: 3 RUNS W/  
 (1) 2" CONDUIT - SIGNALS  
 (1) 2" CONDUIT - SIGN  
 (1) 2" CONDUIT - VIDEO DETECTION

INTERNALLY ILLUMINATED STREET NAME SIGNS  
 SEE GUIDE SIGN WORK SHEET FOR DETAILS



**TABLE 4: CONTROLLER TIMINGS**

TIMING FUNCTION	1	2	3	4	5	6	7	8
MOVEMENT NUMBER	1	2	3	4	5	6	7	8
MINIMUM GREEN	6	16	6	6	6	16	6	6
EXTENSION	3.0	3.0	3.0	3.0	3.0	3.0	3.0	3.0
MAXIMUM GREEN 1	20	50	20	41	20	50	20	42
MAXIMUM GREEN 2								
YELLOW CLEARANCE	5.1	5.1	4.9	4.4	5.1	5.1	4.4	4.9
ALL RED	5.4	2.7	5.3	3.4	5.3	2.7	5.7	3.4
PEDESTRIAN WALK		7		7		7		7
PED. CLEARANCE		29		30		26		39
RECALL		MIN				MIN		

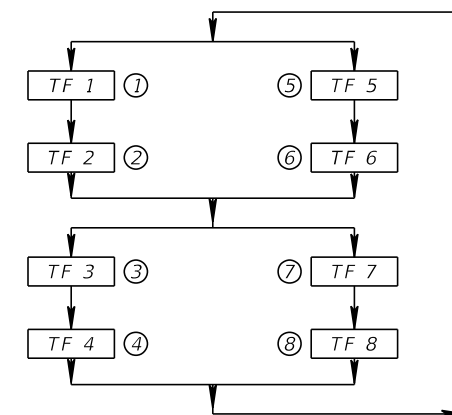
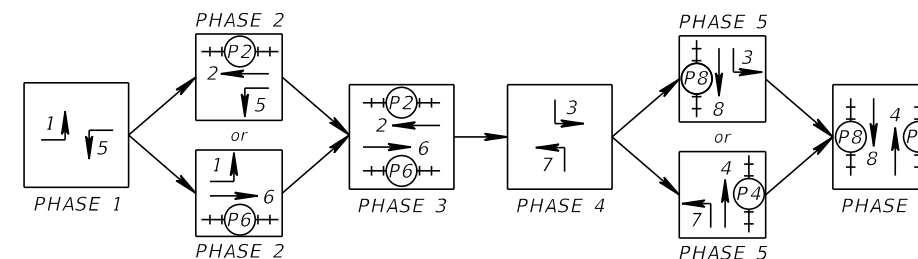

**INTERNALLY ILLUMINATED STREET NAME SIGN NOTES:**

- SIGN "B" ON MAST ARM POLES 1 AND 2 SHALL BE DOUBLE SIDED.
- ALL SIGNS SHALL BE MOUNTED SUCH THAT THEY ARE NORMAL TO THE APPROACHING TRAFFIC.
- WIRING FOR THE SIGNS MOUNTED TO THE BRIDGE UNDERDECK SHALL BE ROUTED THROUGH THE BRIDGE BARRIER WALL AND BRIDGE DECK. SEE STRUCTURAL PLANS FOR ADDITIONAL DETAILS.

REVISIONS				SCOTT G. HORLANDER, P.E. P.E. NO. 46624 PROTEAN DESIGN GROUP 100 EAST PINE STREET, SUITE 600 ORLANDO FLORIDA 32801 CERTIFICATE OF AUTHORIZATION NUMBER 7865	STATE OF FLORIDA DEPARTMENT OF TRANSPORTATION			SIGNALIZATION PLAN SR 500 & SR 46 (CONT.)	SHEET NO. T-6
DATE	DESCRIPTION	DATE	DESCRIPTION		ROAD NO.	COUNTY	FINANCIAL PROJECT ID		
					SR 46	LAKE	238275-2-52-01		







STANDARD MAST ARM ASSEMBLIES DATA TABLE																	Table Date 01-01-12		
STRUCTURE ID NUMBERS	ASSEMBLY NUMBERS <sup>(1)</sup>	FIRST ARM			SECOND ARM			UF (deg)	LL (deg)	POLE				SPECIAL DRILLED SHAFT <sup>(4)</sup>					
		ARM TYPE	FAA <sup>(2)</sup> (ft.)	FBA <sup>(2)</sup> (in.)	ARM TYPE	FAA <sup>(2)</sup> (ft.)	FBA <sup>(2)</sup> (in.)			POLE TYPE	UAA <sup>(3)</sup> (ft.)	UB (ft.)	UCA <sup>(3)</sup> (in.)	DA (ft.)	DB (ft.)	RA	RB	RC	RD (in.)
POLE 1	E6-T4	E6	-	-	-	-	-	-	-	T4	22.0	19.0	18.95	16.5	-	-	-	-	-
POLE 2	E3-T2	E3	-	-	-	-	-	-	-	T2	24.0	21.0	12.67	16.5	-	-	-	-	-

TABLE NOTES [Notes Date 07-01-14]:

- Assembly Number Legend  
 Single Arm:  
 Arm Type - Pole Type = D# - S#  
                               = E# - T#  
  
 Double Arm:  
 First Arm Type - Second Arm Type - Pole Type = D# - D# - S#  
                                                           = E# - E# - T#
- If an entry appears in columns "FAA" and "FBA", a shorter arm is required. This is obtained by removing length from the arm tip. For these cases the mast arm length shall be shortened from "FA" to "FAA" and the tip diameter shall be increased from "FB" to "FBA".
- If an entry appears in columns "UAA" and "UCA", a shorter pole is required. This is obtained by removing length from the pole tip. For these cases the pole height shall be shortened from "UA" to "UAA" and the pole tip diameter shall be increased from "UC" to "UCA".
- The foundations for Standard Mast Arm Assemblies are pre-designed and are based upon the following conservative soil criteria which covers the great majority of soil types found in Florida. Only complete the "Special Drilled Shaft" data information if site conditions dictate drilled shafts with additional foundation capacity.  
  
 Classification = Cohesionless (Fine Sand)  
 Friction Angle = 30 Degrees (30°)  
 Unit Weight = 50 lbs. / cu. ft. (assumed saturated)  
 N-blowcount = 15

GENERAL NOTES:

- Work this sheet with the Signal Designer's "Mast Arm Tabulation". See "Mast Arm Tabulation" for special instructions that include non-standard Handhole location, paint color, terminal compartment requirement, and pedestrian features.
- Work with Index Nos. 17743 and 17745.

REVISIONS						MOFFATT & NICHOL 1025 GREENWOOD BLVD, STE 371 LAKE MARY, FL 32746 PHONE (407) 562-2030 CERT. OF AUTH. NO. 4877	DRAWN BY: CSG CHECKED BY: GAP DESIGNED BY: JDG CHECKED BY: GWS	STATE OF FLORIDA DEPARTMENT OF TRANSPORTATION			SHEET TITLE: <b>STANDARD MAST ARM ASSEMBLIES DATA TABLE</b>		REF. DWG. NO.
DATE	BY	DESCRIPTION	DATE	BY	DESCRIPTION			ROAD NO.	COUNTY	FINANCIAL PROJECT ID	PROJECT NAME: WEKIVA PARKWAY US 441 FLYOVER RAMP XX MSE WALLS		SHEET NO. T-9

NOTICE: THE OFFICIAL RECORD OF THIS SHEET IS THE ELECTRONIC FILE SIGNED AND SEALED UNDER RULE 61G15-23.004, F.A.C.

ELEVATION (FT., NAVD88)

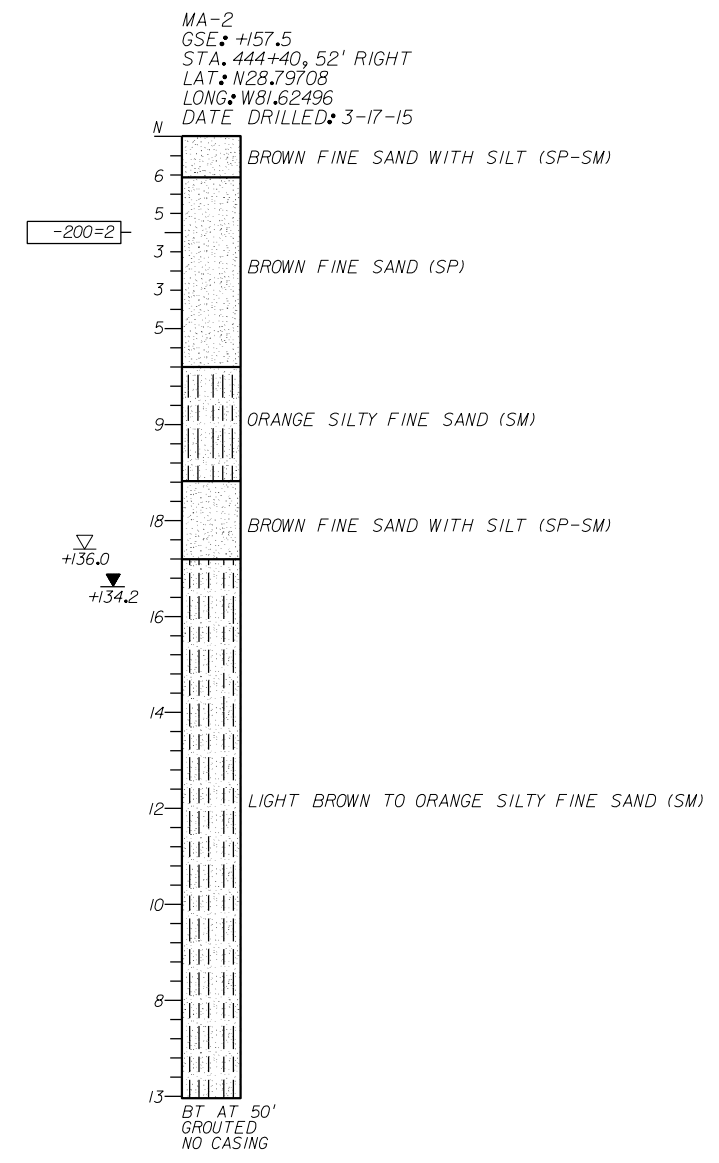
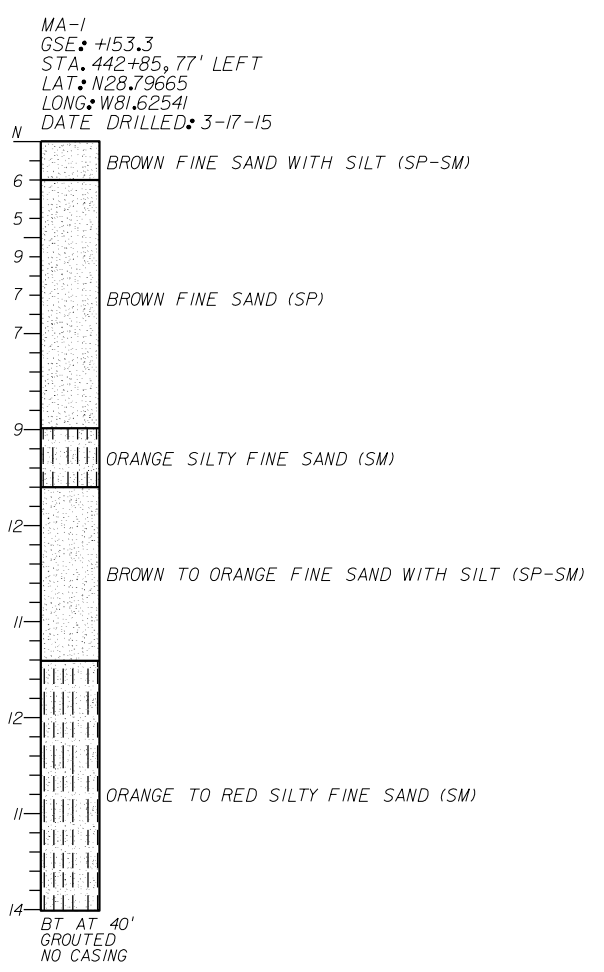

**LEGEND**

- ▽ +135.3 ESTIMATED SEASONAL HIGH GROUNDWATER ELEVATION (FT. NAVD88)
- ▽ +133.9 ENCOUNTERED GROUNDWATER ELEVATION (FT. NAVD88) 24 HRS. AFTER DRILLING BORING
- GSE GROUND SURFACE ELEVATION (FT. NAVD88)
- N STANDARD PENETRATION RESISTANCE, BLOWS PER FOOT
- (SP) UNIFIED SOIL CLASSIFICATION SYMBOL
- BT BORING TERMINATED AT SPECIFIED DEPTH (FEET) INDICATED
- 200= PERCENT PASSING NO. 200 U.S. STANDARD SIEVE (FM 1-T 088)

**SOILS LEGEND**

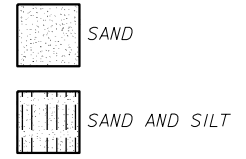

**GENERAL NOTES**

STANDARD PENETRATION TEST BORINGS WERE PERFORMED IN ACCORDANCE WITH ASTM D-1586. STANDARD PENETRATION RESISTANCES ARE SHOWN ON THE BORINGS AT THE TEST DEPTHS IN BLOWS PER FOOT UNLESS OTHERWISE NOTED.

SUBSURFACE CONDITIONS SHOWN ON THE BORINGS REPRESENT THE CONDITIONS ENCOUNTERED AT THE BORING LOCATIONS. ACTUAL CONDITIONS BETWEEN BORINGS MAY VARY FROM THOSE SHOWN. UNIFIED SOIL CLASSIFICATIONS SHOWN ON THE BORINGS ARE BASED ON VISUAL EXAMINATION AND THE LABORATORY TESTING SHOWN.

THE BORING LOCATIONS WERE NOT SURVEYED. BORING LOCATIONS WERE ESTABLISHED IN THE FIELD USING A SUB-METER ACCURACY GPS UNIT (TRIMBLE TX) FOR HORIZONTAL AND VERTICAL CONTROL. GROUND SURFACE ELEVATIONS ESTIMATED FROM PROJECT CROSS SECTIONS. BORING LOCATION (SB-1) REFERENCES SR 46 CENTERLINE. BORING LOCATION (SB-2) REFERENCES US 44 CENTERLINE.

BASED ON REVIEW OF THE U.S. GEOLOGICAL SURVEY MAP ENTITLED "POTENTIOMETRIC SURFACE OF THE UPPER FLORIDAN AQUIFER IN ST. JOHNS RIVER WATER MANAGEMENT DISTRICT AND VICINITY, FLORIDA, SEPTEMBER 2008" FOR THE PROJECT AREA, THE MAXIMUM ELEVATION OF THE ARTESIAN HEAD IS ESTIMATED TO BE +55 FT. NAVD88. THE CONTRACTOR SHALL BE PREPARED TO HANDLE ARTESIAN HEAD LEVELS UP TO +55 FT. NAVD88.

SPLIT SPOON SAMPLER: AVERAGE HAMMER DROP: 30 IN.  
 INSIDE DIAMETER: 1.375 IN. HAMMER WEIGHT: 140 LBS.  
 OUTSIDE DIAMETER: 2.0 IN. HAMMER TYPE: AUTOMATIC

**CORRELATION OF STANDARD PENETRATION RESISTANCE WITH RELATIVE DENSITY AND CONSISTENCY OF SOIL**

GRANULAR SOILS	N VALUE (blows per foot)	RELATIVE DENSITY
SANDS	0-3	VERY LOOSE
	3-8	LOOSE
	8-24	MEDIUM DENSE
	24-40	DENSE
	OVER 40	VERY DENSE
NON-GRANULAR SOILS	N VALUE (blows per foot)	CONSISTENCY
SILTS, CLAYS, MUCK, PEAT	0-1	VERY SOFT
	1-3	SOFT
	3-6	FIRM
	6-12	STIFF
	12-24	VERY STIFF
	OVER 24	HARD

**FIGURE 32**

REVISIONS				<b>GEOTECHNICAL AND ENVIRONMENTAL CONSULTANTS, INC. (GEC)</b> 919 Lake Baldwin Lane Orlando, FL 32814 T 407-898-1818 F 407-898-1837 Certificate of Authorization No. 5882 <b>CRAIG G. BALLOCK P.E. 71571</b>	STATE OF FLORIDA DEPARTMENT OF TRANSPORTATION			<b>REPORT OF SPT BORING RESULTS FOR MASP</b>	SHEET NO.
DATE	DESCRIPTION	DATE	DESCRIPTION		ROAD NO.	COUNTY	FINANCIAL PROJECT ID		
					SR 46	LAKE	238275-2-52-01		T-10

NOTICE: THE OFFICIAL RECORD OF THIS SHEET IS THE ELECTRONIC FILE SIGNED AND SEALED UNDER RULE 61G15-23.003, F.A.C.

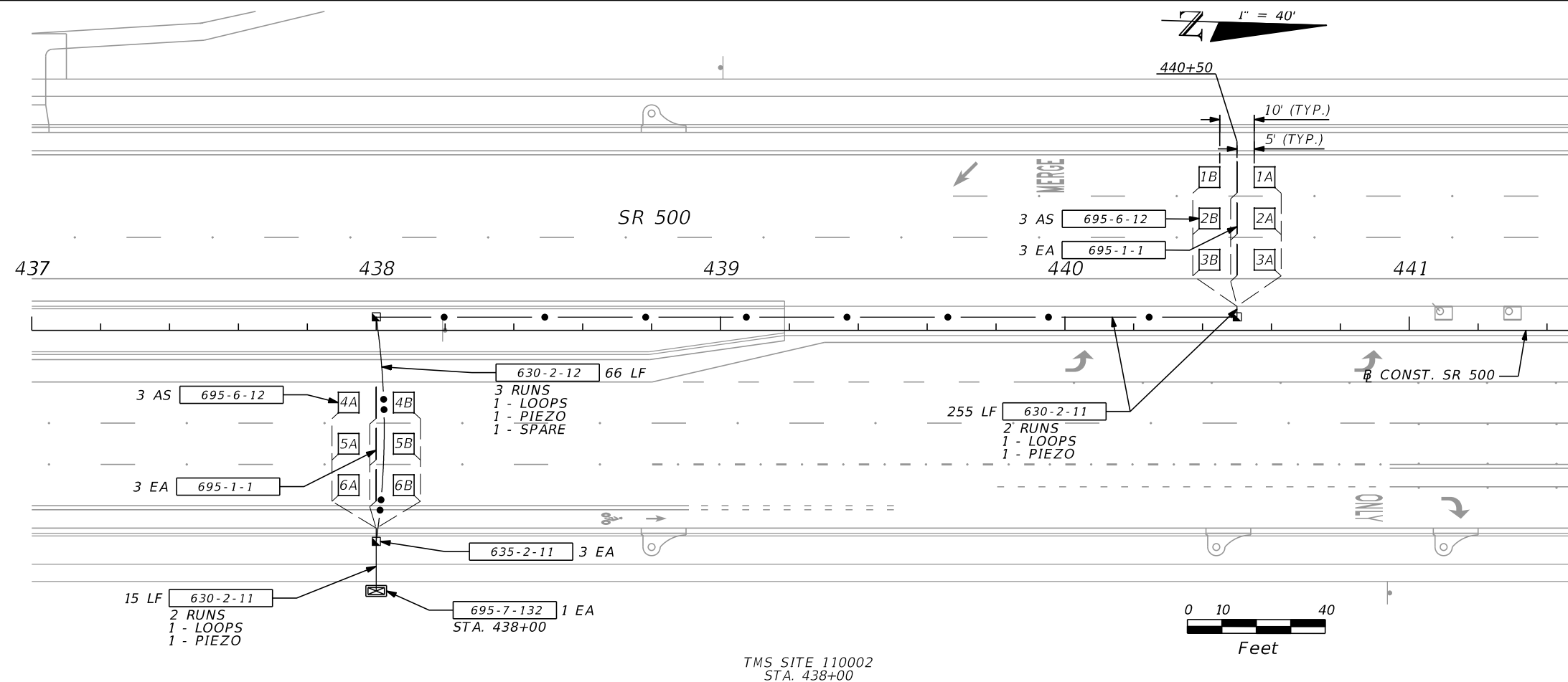

### STANDARD NOTES FOR TRAFFIC MONITORING SITES

1. NOTIFY THE DISTRICT TRAFFIC OPERATIONS OFFICE ALONG WITH PROJECT ADMINISTRATOR AT LEAST TEN (10) WORKING DAYS PRIOR TO BEGINNING ANY WORK. CONTACT THE DISTRICT DATA COLLECTION MANAGER AT (386) 943-5380 TO CONFIRM LOCATION. ANY CHANGES MUST BE APPROVED BY THE DISTRICT TRAFFIC OPERATIONS OFFICE.
2. PROVIDE A NEW PEDESTAL-MOUNTED TYPE III TRAFFIC COUNT CABINET W/ 2 BACKPLANES, FURNISHED AND INSTALLED PER DESIGN STANDARDS.
3. FURNISH AND INSTALL PIEZOELECTRIC AXLE SENSOR AND SPEED CLASSIFICATION LOOP ASSEMBLIES PER DESIGN STANDARDS.
4. IMMEDIATELY AFTER COMPLETION OF INSTALLATION, CONTACT THE DISTRICT DATA COLLECTION MANAGER @ 386-943-5380 PRIOR TO FINAL ACCEPTANCE.

REVISIONS				SCOTT G. HORLANDER, P.E. P.E. NO. 46624 PROTEAN DESIGN GROUP 100 EAST PINE STREET, SUITE 600 ORLANDO FLORIDA 32801 CERTIFICATE OF AUTHORIZATION NUMBER 7865	STATE OF FLORIDA DEPARTMENT OF TRANSPORTATION			TRAFFIC MONITORING SITE	SHEET NO.
DATE	DESCRIPTION	DATE	DESCRIPTION		ROAD NO.	COUNTY	FINANCIAL PROJECT ID		T-11
					SR 46	LAKE	238275-2-52-01		